

# Mobile 75 H + H WB

Electro-hydraulic mobile lift with 7.5 t capacity per column



## Application

- Repair and maintenance

## Description:

- Self-carrying hydraulic cylinders
- Encased cylinders
- Spring-loaded wheel with locking device on column back
- Fixed  $\varnothing 125$  mm wheel on column front
- Encased cylinders

### All wheel sizes:

- $\varnothing 550-1,140$  mm
- Fork length 300 mm
- Integrated towing jack on each column

### Standard colours:

- Columns: RAL 7016 - grey
- Wheel forks: RAL 3020 - red

## Versions:

- Cable version:  
with 2 or 4 columns
- Wireless version:  
up to 10 columns

## Optional extras:

- Traverse, 15 t
- Support for traverse
- Support stand, 880-1410 mm,  
8.2 t
- Support stand, 1350-2130 mm,  
8.2 t
- Adjustable wheel
- Remote control for cable version

**Special colours available  
on request!**



Scan the QR-Code for detailed product information.

Further Information on [www.autopstenhoj.com](http://www.autopstenhoj.com)

**autop Maschinenbau GmbH**

Sandkampstraße 90  
48432 Rheine | Germany

☎ +49 5971 8602-02

📠 +49 5971 8602-25

✉ info@autopstenhoj.com

**STENHØJ A/S**

Barrit Langgade 188-190  
DK-7150 Barrit

☎ +45 76 82 13 30

📠 +45 76 82 13 31

✉ info@autopstenhoj.com

**Technical data**

Lifting capacity	7,500 kg
Lifting height	1,800 / 1,850 mm
Stroke length	1,700 / 1,750 mm
Lifting / lowering time	135 / 90 sec.
Pump unit	1.1 / 2.2 kW
Operation	hydraulic
Voltage	3 x 230 / 400V – 50 Hz – 25/16 A
Min. height	155 / 140 mm
Total height	3,700 / 3,770 mm

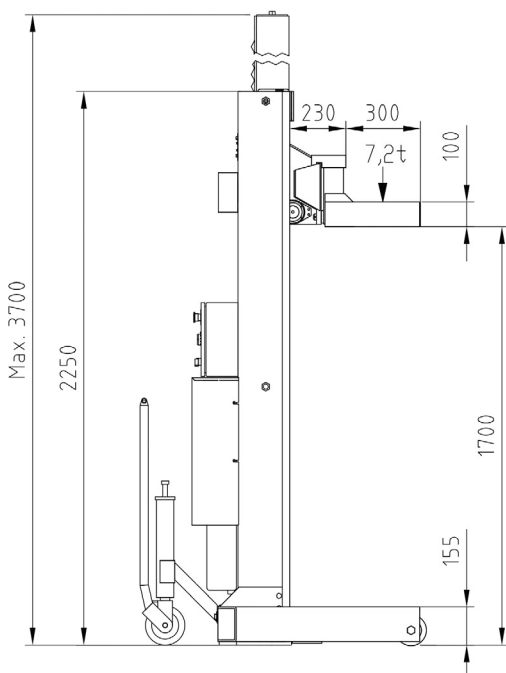
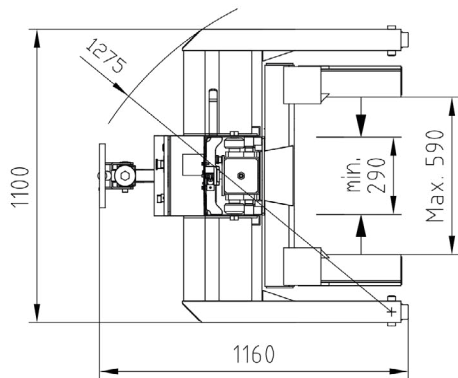

Fork



Remote control for cable version



Support stands in different heights