

Stenhøj Maestro 2.35

Stenhøj Maestro 2.35

2-post electro-mechanical lifts

The STENHØJ Maestro 2.35 lifts are electro-mechanical asymmetric lifts with lifting capacities of 3.5 t.

Maestro 2.35 has been developed especially to offer high flexibility and optimized lifting capacity for workshops servicing both small cars, transporters and pick-up trucks.

Maestro 2.35 is available with either flex pads or our new combiflex-08 pads and has a programmable top stop.



We offer a large program of both U and flex pads for the F-models.

Flex pad:
Min. height: 85 mm.
Max. height: 115 mm

Combiflex-08 pad:
Min. height: 95 mm
Max. height: 250 mm



STENHØJ
lifting the level

Stenhøj Maestro 2.35

Stenhøj Maestro 2.35

2-post electro-mechanical lifts

We can now offer three auxiliary packages:

Package 1 :
Air and power unit
Extra control unit
Rechargeable LED lamp

Package 2:
Air and power unit
Extra control unit

Package 3:
Air and power unit
Rechargeable LED lamp



Extensions (optional extras) for the Maestro 2.35 makes it possible to lift even very long vans.

Internal arm locking device that automatically releases in bottom position.

Control unit with dead-man controls and separate main switch.



STENHØJ
lifting the level

Stenhøj Maestro 2.35

Stenhøj Maestro 2.35

2-post electro-mechanical lifts

Maestro 2.35 is now equipped with newly designed door stops; and can be delivered with collapsible wheel holders (optional extras).

A 400 V Maestro 2.35 has a lifting time of only 35 seconds – perhaps the quickest on the market.

A 220 V version has a lifting time of 42 seconds.



Nut breakage system.

The most durable nut set on the market.



6 large guiding wheels.



Cold-rolled, centered spindle for very long life.



STENHØJ
lifting the level

Stenhøj Maestro 2.35

CORROSION-PROOF SURFACE TREATMENT

All Stenhøj lifts are led through a sling purifying plant (according to SA2.50 – ISO-Norm 8501-1:2007), dipped in primer, and finally led through an electro-static powder bake plant.

Technical data

Lifting capacity	3500 kg
Lifting/lowering time	35 sec. (400 V)
Motor	2 x 2.8 kW

Model	A	B	C	D	E	F	G	H	I	J	K	L	
F	3410	2580	3120	3320	4050/4350	2713	1900	2020	2290	550	465	Ø120	
CF-08	3410	2580	3120	3320	4050/4350	2713	1900	2030	2290	550	465	Ø120	
	M	N	O	P	*Q	V	R	S	T	U	W	X	Y
F	600	1220	900	1425	200	95	115	85			100	190	260
CF-08	800	1425	920	1440		92	250	95					

* Q = extension for F (optional extra)

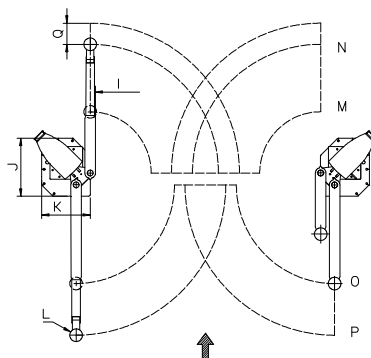
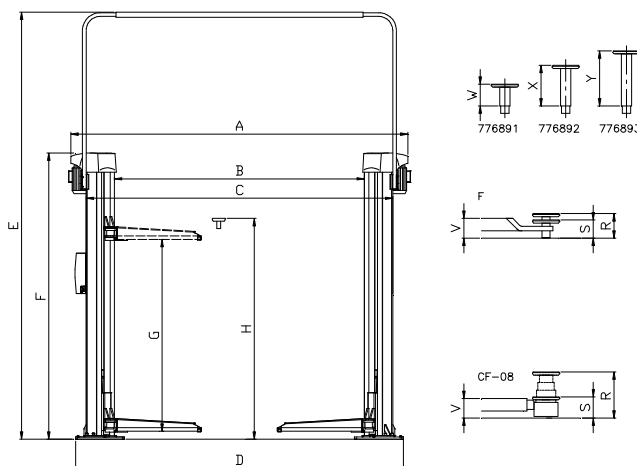

STENHØJ
lifting the level

Stenhøj A/S
Denmark

Tel: +45 76 82 13 30
Fax: +45 76 82 13 31
Mail: info@stenhoj.dk
Web: www.stenhoj.dk

Standard colours

Red RAL 3013
White RAL 9002

No liability accepted for specifications, which are subject to alteration.